

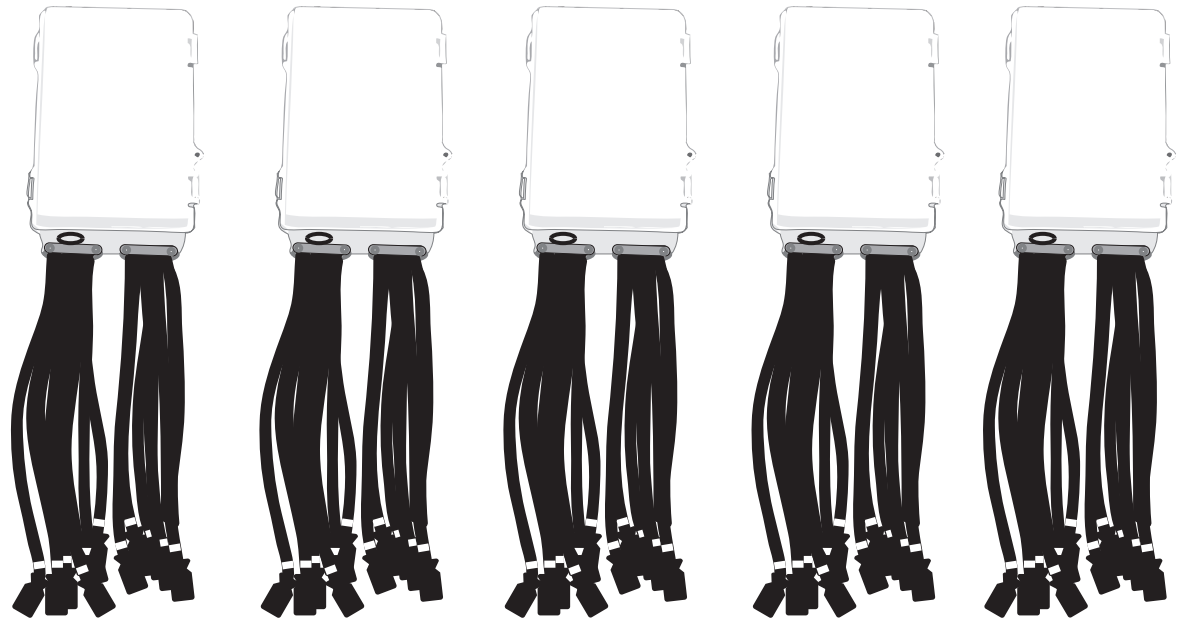

Network Configurations

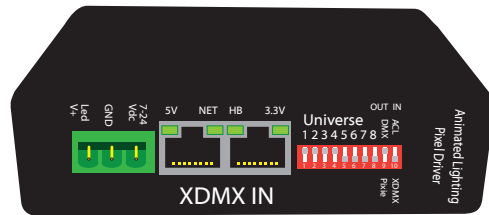

Typical Network Configurations

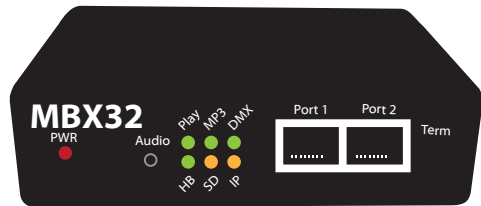
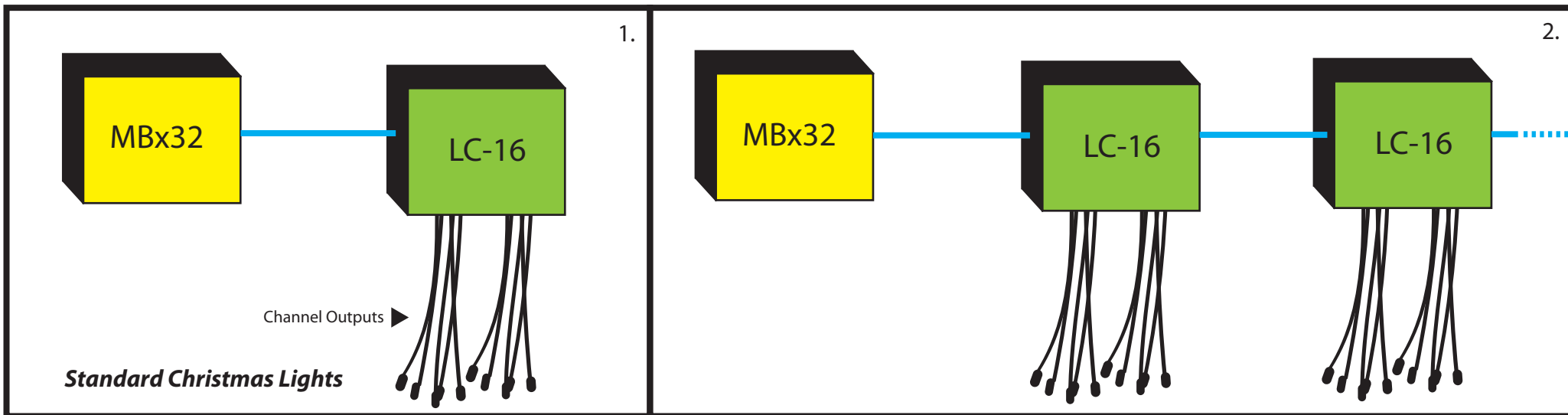

1. The most common network configuration is (1) MBx32 MonsterBrain and (1) LC-16 light controller - 16 standard lighting channels are possible. To learn more about lighting channels, see our manual titled "Channels and Controller Addresses".

2. The next common network option is to add more light controllers. This picture shows 2, but you can add up to 255 light controllers per MBx32. Each LC-16 light controller can control up to 16 lighting channels. (255) LC-16 light controllers would give you up to 4080 standard light channels.

3. Wireless connectivity is also popular in areas with wiring restrictions. This is generally required when a wire needs to cross driveways, walkways, sidewalks and roads.

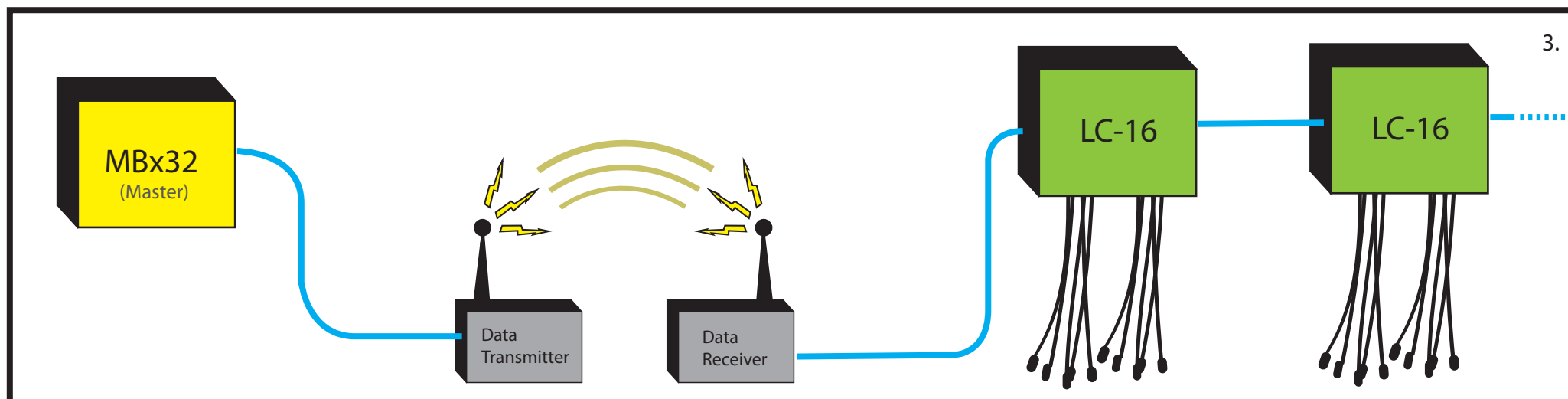

Typical Network Configurations

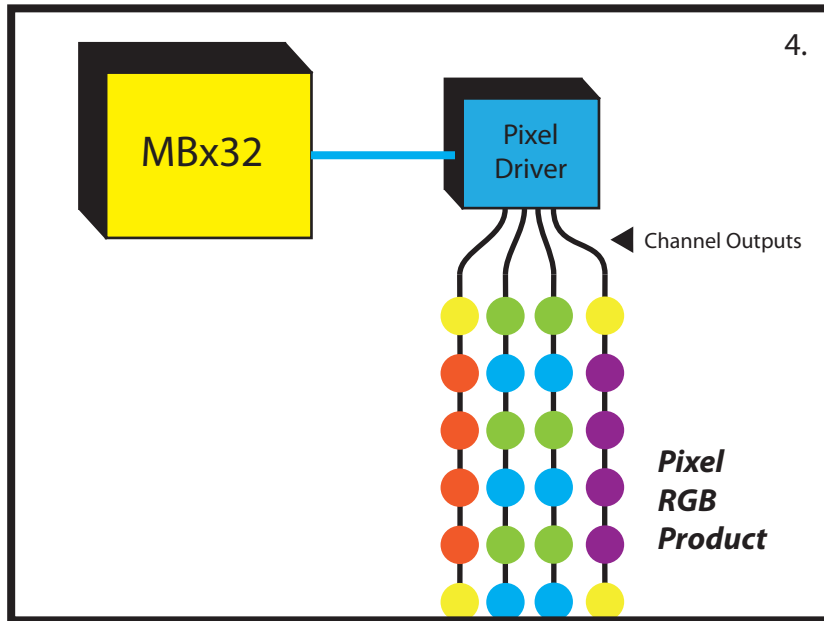

4. The newest technology that we offer at Animated Lighting is RGB Pixel control. Instead of the LC-16 light controller, RGB pixels require a controller called a Pixel Driver. The Pixel Driver controllers control our Pixel360, Pixy, Orb, Tube, Chip3 and Chip6 RGB products. Each bulb is individually controlled. Some of our Just Add Power RGB products include RGB Arches, RGB Stars and Snowflakes, 3D RGB Star and more. All of these products are controlled using the Pixel Driver.

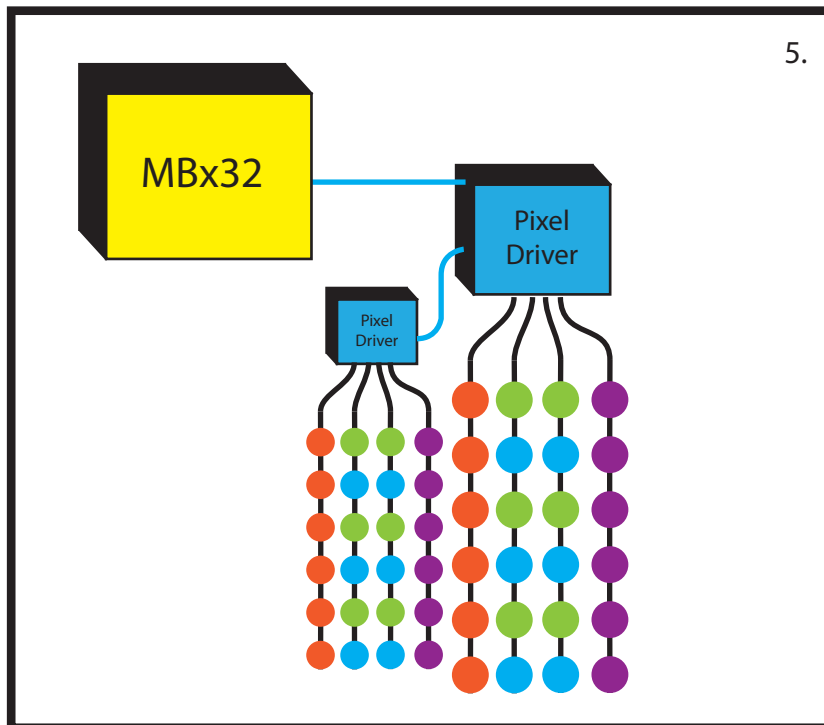

5. You can connect up to 2 Pixel Drivers at a time to a single MBx32 MonsterBrain. Each Pixel Driver can control up to 680 RGB pixels (2040 channels). Those in the theatrical industry would understand when we say that the Pixel Driver can control 4 universes (A unit of measure concerning number of channels). As we said before, 1 MonsterBrain can control 2 Pixel Drivers, which is 8 universes worth of channels. If more RGB pixel channels are required, please see the diagram in the following pages that explains Master/Slave operations with multiple MBx32 devices.

NOTE

Notice this diagram uses **blue** and **black** cables. The **blue** cables are all network cables (CAT5). The **black** cables are Pixel RGB cables. All other cables are labeled.

Typical Network Configurations

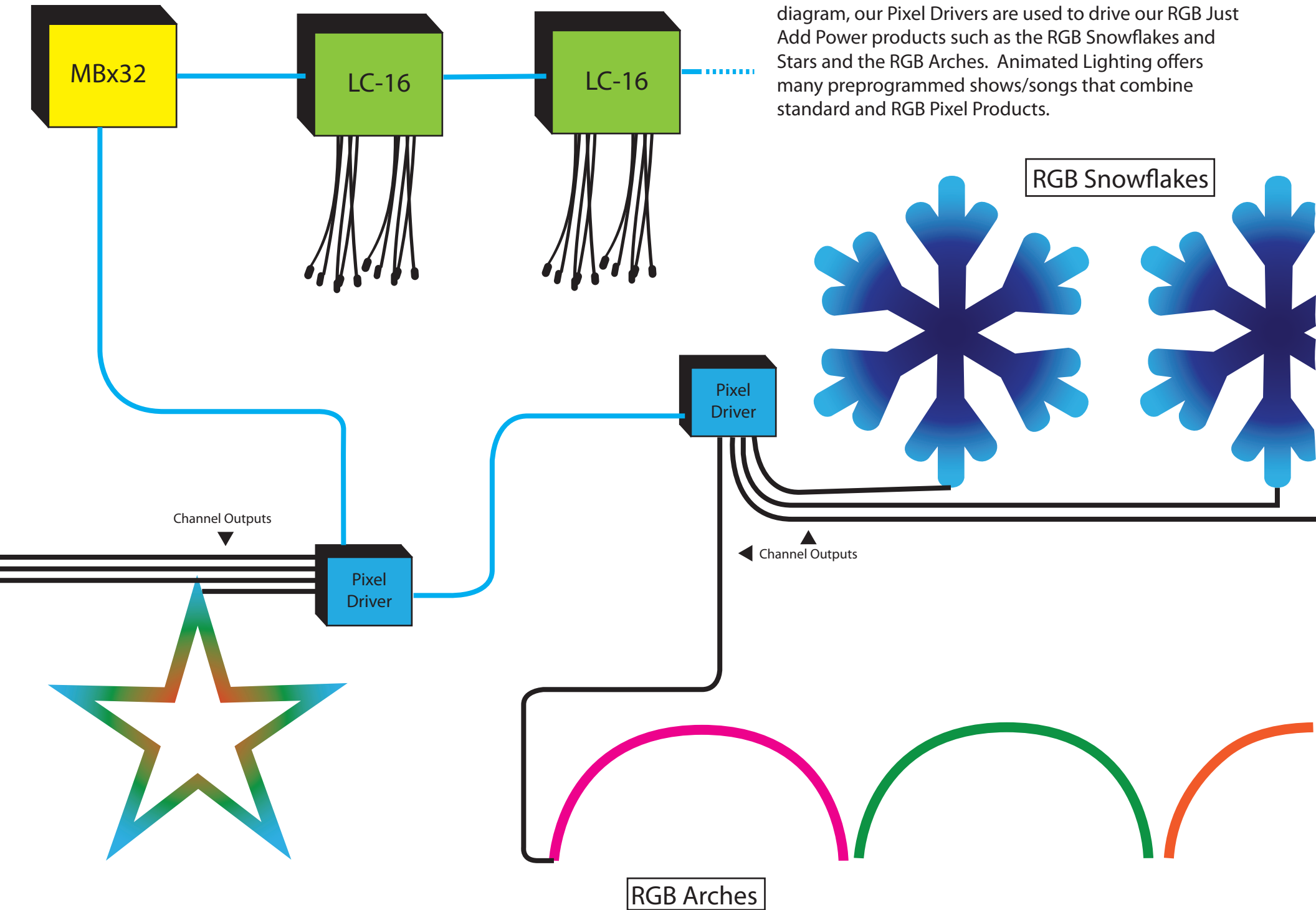

A single MBx32 can be used to control BOTH the LC-16 controllers and the Pixel Drivers. Also shown in this diagram, our Pixel Drivers are used to drive our RGB Just Add Power products such as the RGB Snowflakes and Stars and the RGB Arches. Animated Lighting offers many preprogrammed shows/songs that combine standard and RGB Pixel Products.

Networks that use more than one MBx32

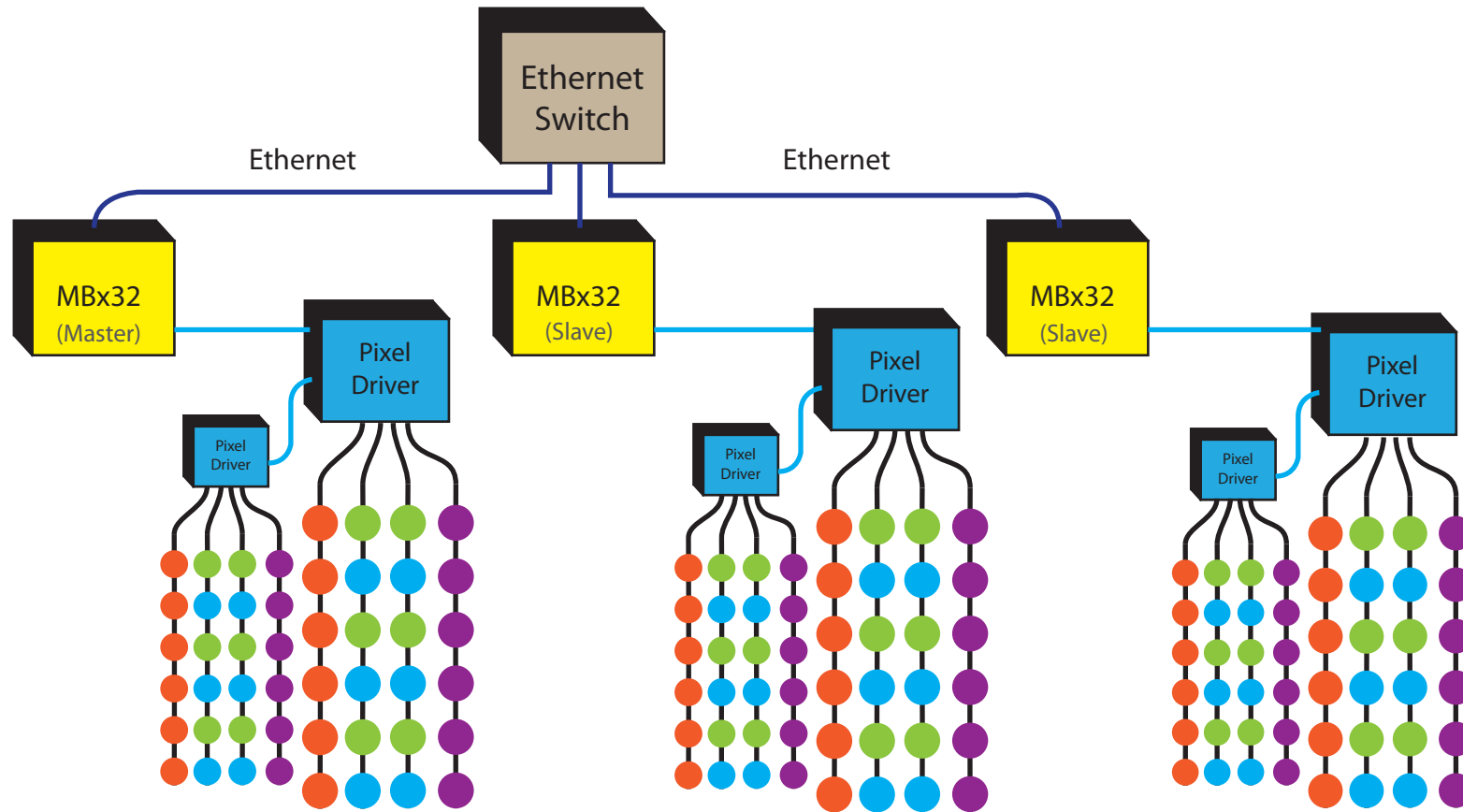

For our customers that require more than 2 Pixel Drivers, we use multiple MBx32 MonsterBrains networked together with an Ethernet switch. This allows us to connect as many Pixel Drivers together as we would like. We run these in what is called Master/Slave mode. A single MBx32 is chosen to be the master and that unit sends commands to all of the others. Very large networks can be achieved with ease.

Large Network Configurations

Large networks can be comprised of many building blocks including new RGB pixel elements, traditional dmx fixtures and standard LC-16 controllers alike.

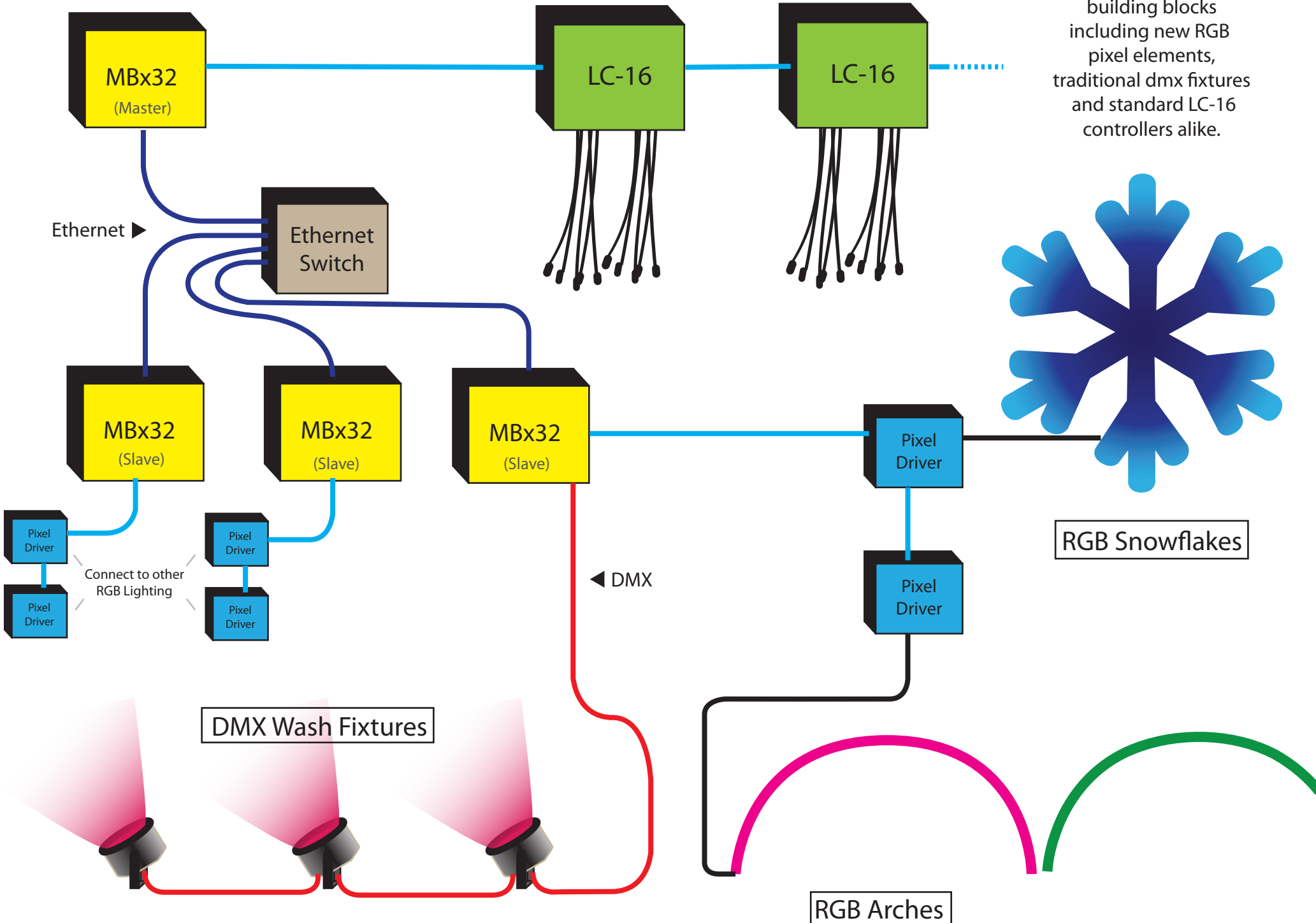

RGB Snowflakes



DMX Wash Fixtures



RGB Arches

Low-Cost Wireless Solution for Networks with Wiring Restrictions

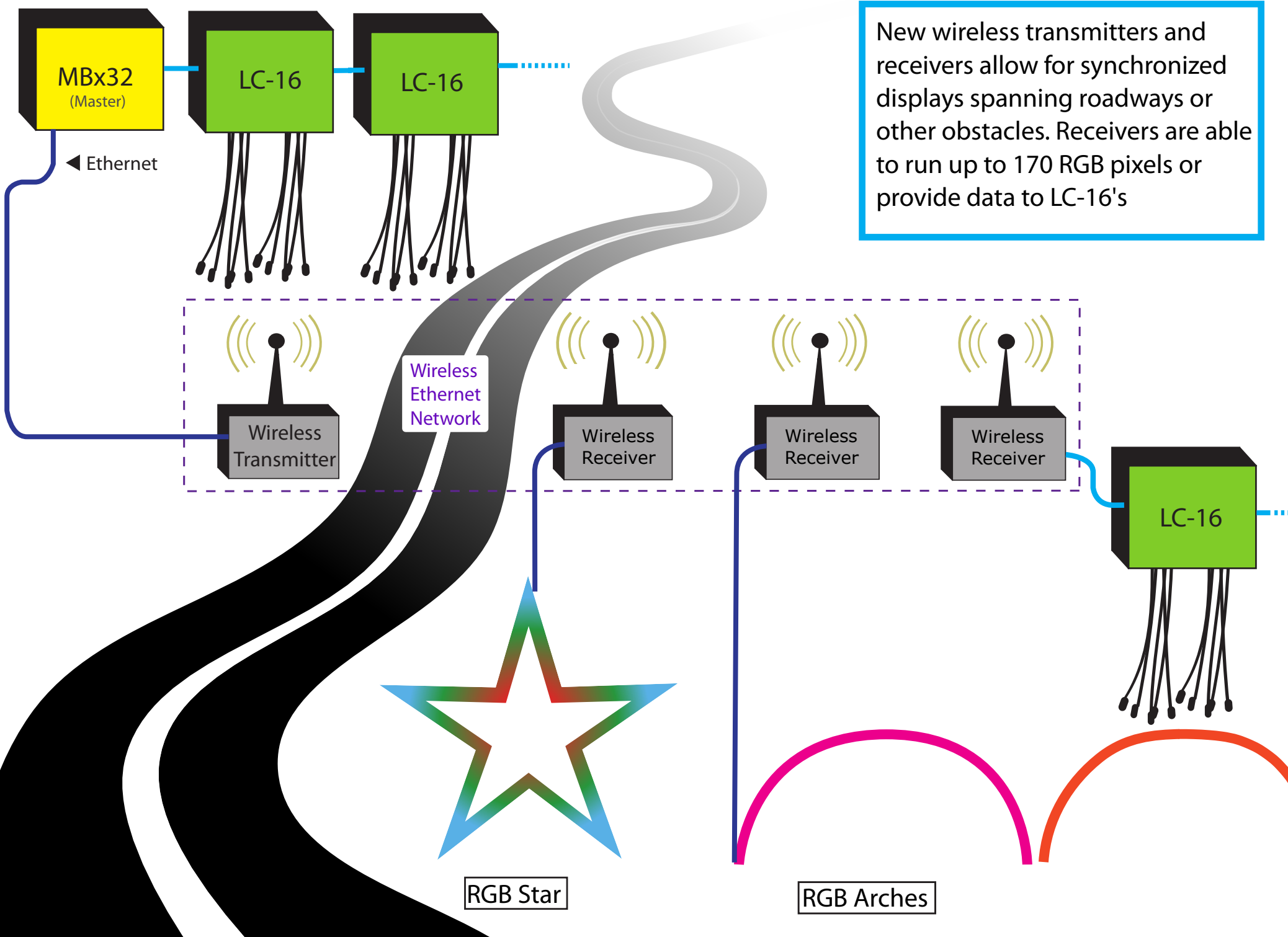

Wireless Solutions for Larger Networks or Areas with Wiring Restrictions

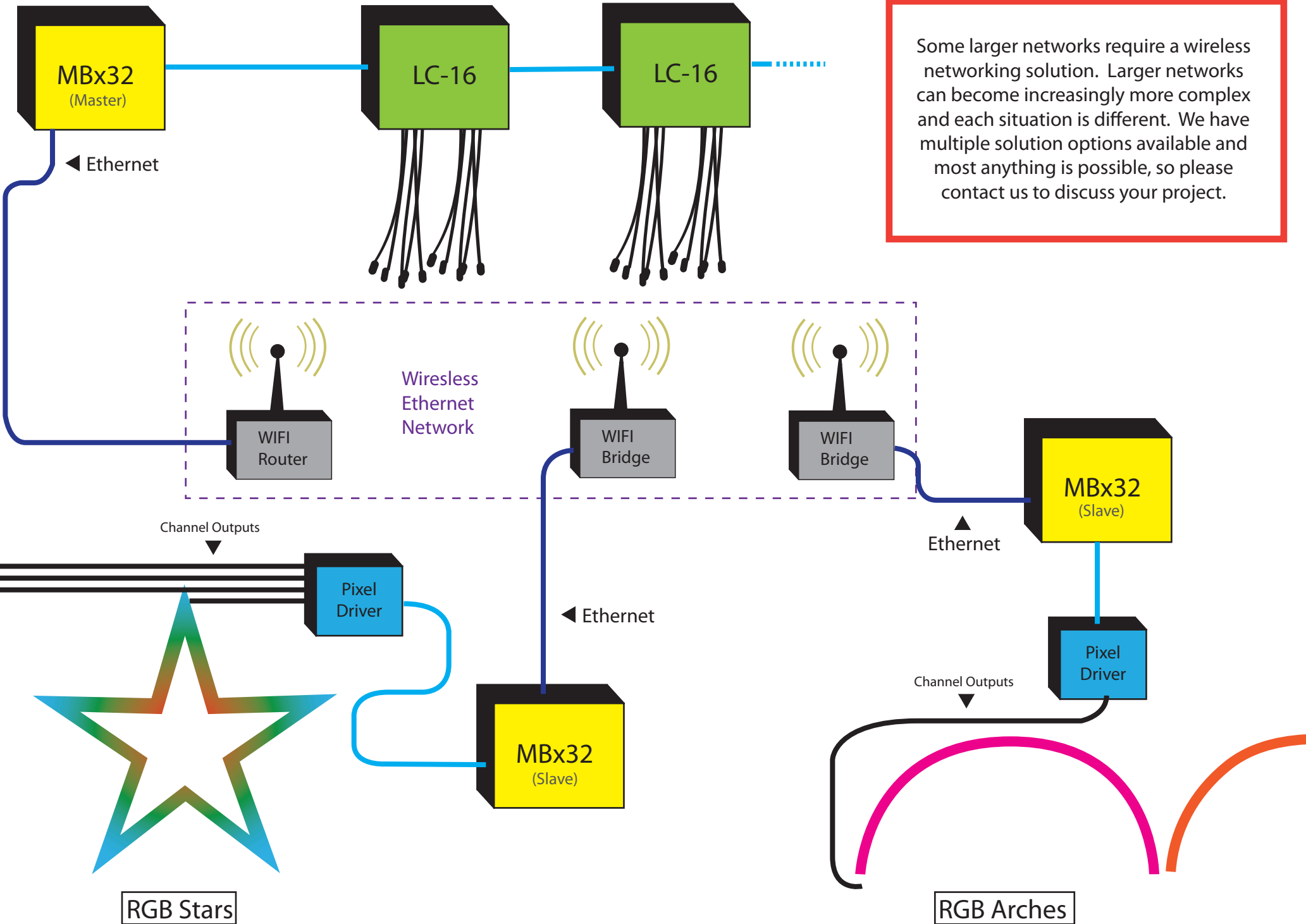

There's an App for that

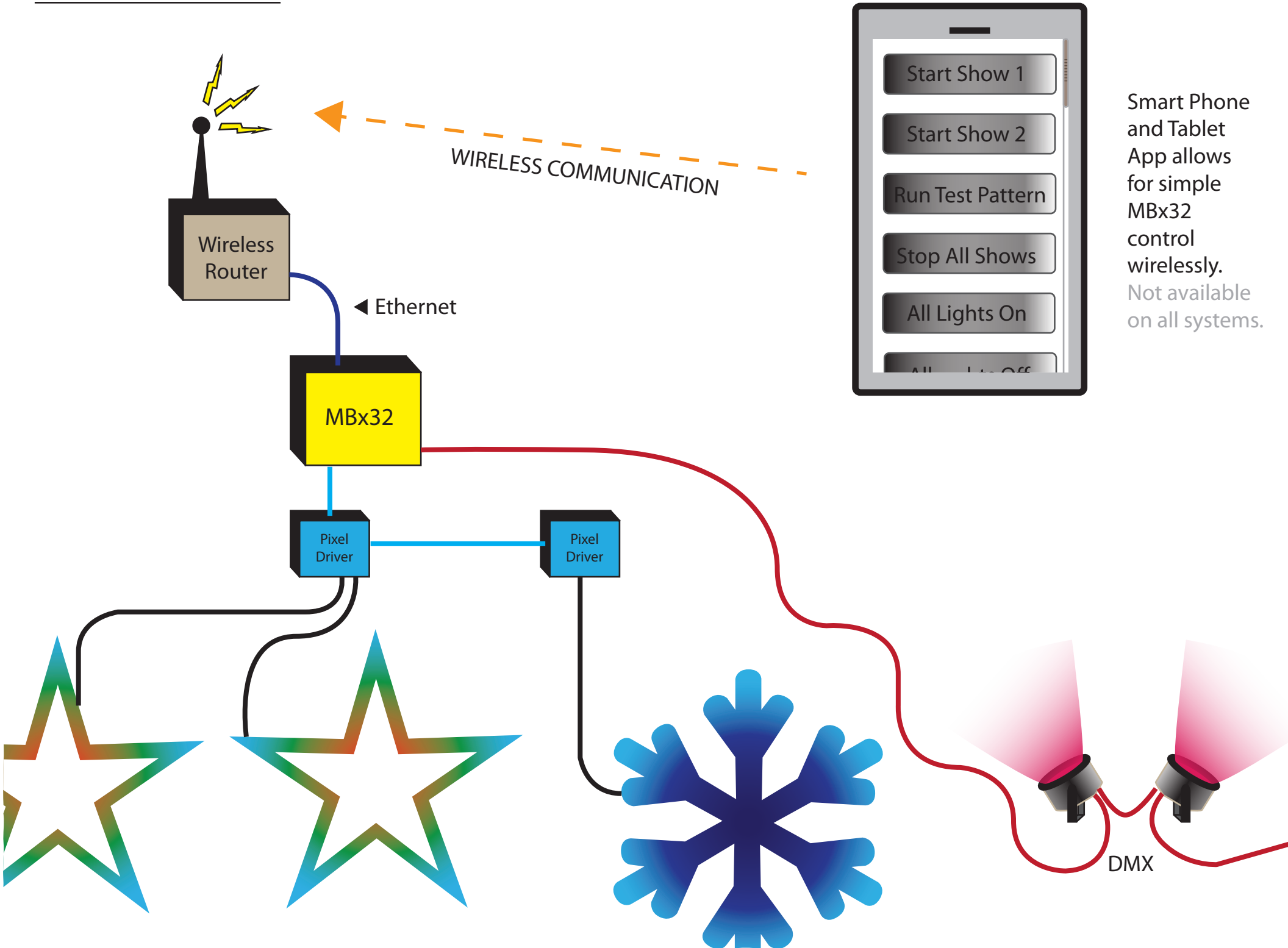

Run Shows Live

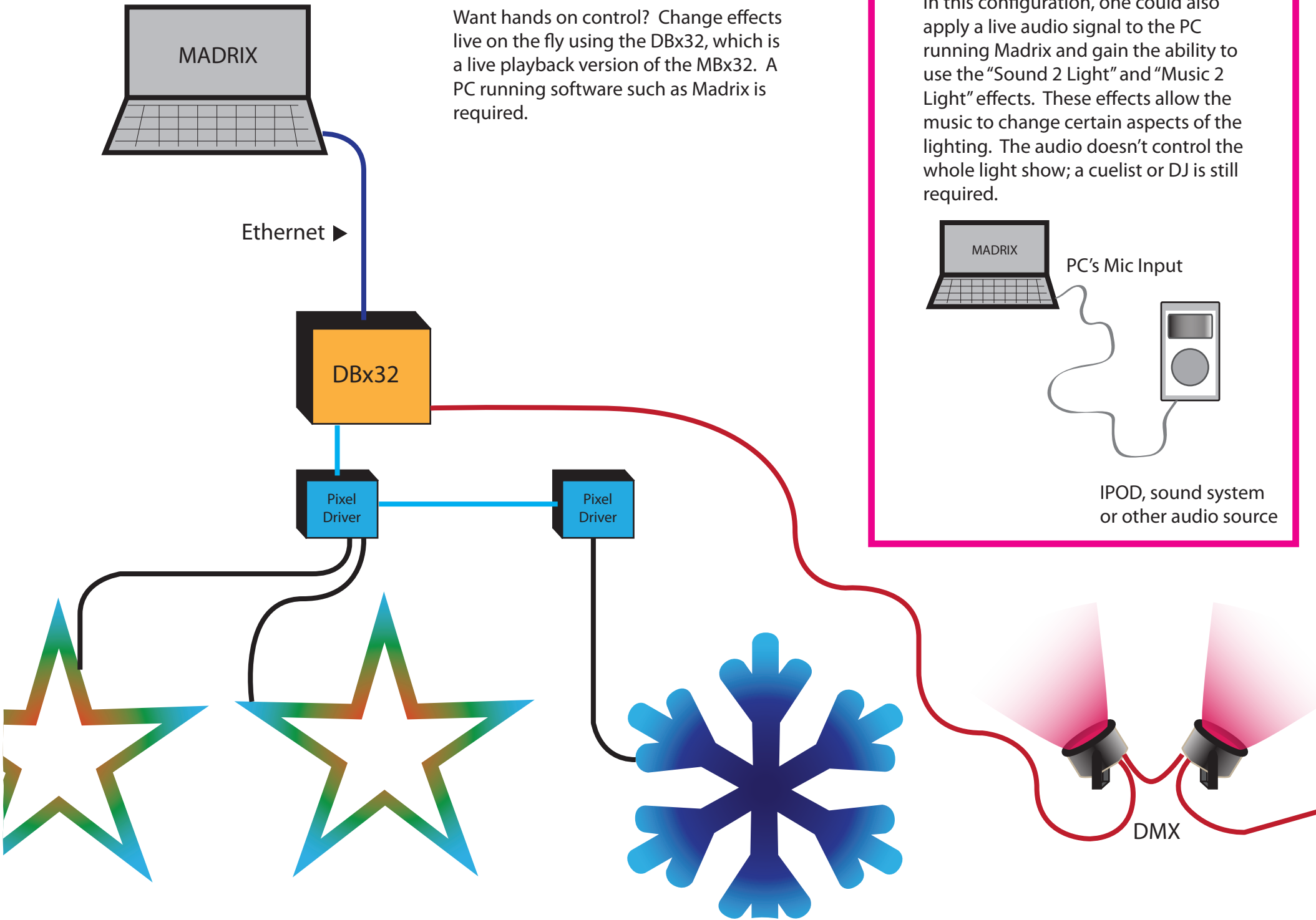



Telephone - (816) 941-0400

Email - sales@animatedlighting.com

Questions, concerns, don't know how or where to get started? Contact us today!